

Affilatoio amovibile incluso.  
Removable sharpener included.



Pressamerce con protezione in plexiglass.  
Food-holder arm with protection in plexiglass.

## Caratteristiche

- Basamento pressofuso in alluminio laccato con doppia mano di vernice più trasparente uso alimentare.
- Coprilama e piatto in alluminio fuso stampato protetto con ossidazione anodica.
- Albero portalama montato su doppio cuscinetto a sfere.
- Motore professionale ventilato.
- Lama professionale, temperata, rettificata e cromata a cromo duro.
- Anello fisso di protezione della lama.
- Pressamerce in alluminio protetto con ossidazione anodica.
- Vela in alluminio fuso stampato protetto con ossidazione anodica.
- Spessore di taglio fino a 14 ÷ 16 mm.

## Features

- Die-cast casing in lacquered aluminium with two coats of paint and one of transparent for contact with food.
- Blade cover and food tray in die-cast aluminium protected by an anodic oxidation.
- Shaft holding the blade mounted on a double ball-bearing.
- Professional ventilated motor.
- Professional tempered ground hard chromium-plated blade.
- Fixed blade protection ring.
- Food holder arm in anodized aluminium.
- Sail-shaped rest in die-cast aluminium protected by an anodized oxidation.
- Slicing thickness up to 14 ÷ 16 mm.

## DIMENSIONI - DIMENSIONS

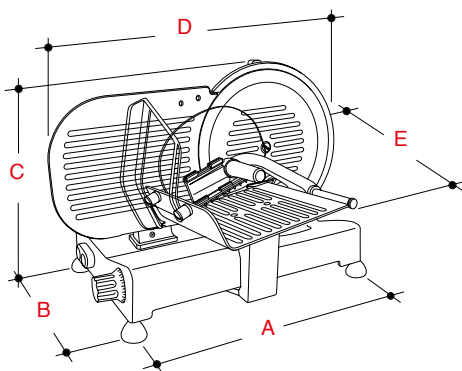

A	B	C	D	E
mm	mm	mm	mm	mm
400	250	360	520	450



Manopola graduata ed interruttore per centralina CEV.  
Graduated knob and switch linked to CEV control unit.

SERIE LUSSO	Diametro lama Blade diameter	Potenza motore Power	Capacità di taglio Cutting capacity	N° giri lama Saw blade speed	Corsa carrello Trolley run	Peso netto Net weight	imballo Packing
	mm	Watt	±5 mm	g/min. (RPM)	mm	Kg	cm
<b>MOD 275 A CEV</b>	275	150	230 x 190	320	255	16	51x62x47 (0,15m³)